

# PRECISION VISE



Premium steel



Convenient



High precision



Durable



Quality assurance



**Strong clamping**  
**Sturdy and durable**

- ✓ Suitable for heavy cutting
- ✓ High clamping precision
- ✓ Horizontal, vertical, lateral use

**Easy to operate**  
**Quick tool change**

- ✓ Heat-treatable
- ✓ High tensile strength
- ✓ Multi-functional cutting

# 5-AXIS AIR VISE PSC

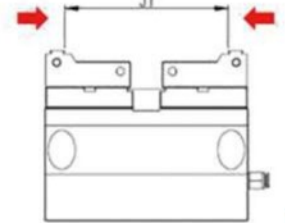
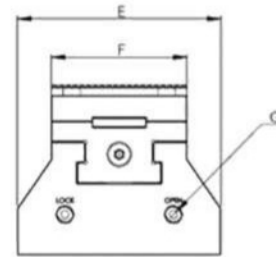
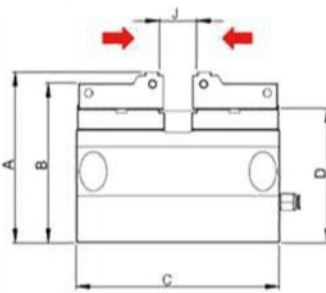

▼ Adjustable block extends gripping distance.

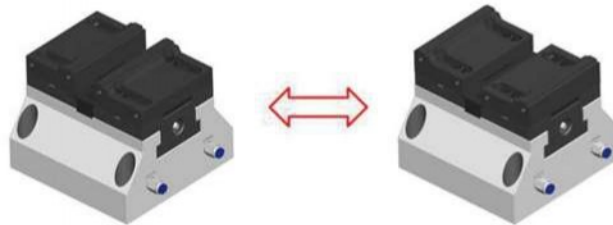

▼ Flexible use of the movable block for diverse clamping needs.

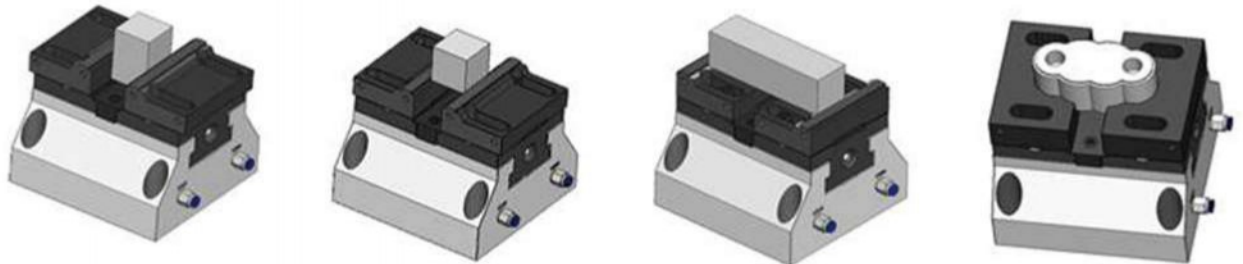

## Specifications

- ▶ It offers high repeatability in clamping and positioning accuracy, up to 0.01mm. It is suitable for precise machining in 4-axis and 5-axis CNC machine tools, indexing heads, and precision vertical/horizontal machining centers.
- ▶ Fast clamping switch for automated production with machines and robots.
- ▶ HRC45° hardness for gripping high-hardness materials.
- ▶ High strength, wear resistance, and tensile strength.

訂購編號 Order No.	規格 Spec	A	B	C	D	E	F	G	J	J1	Clamping form	Max clamping force	Weight	庫存 Stock	牌價 P	備註2 Remark2
LPSC100	PSC-100	124	116	150	100	150	100	Ø8	27.5	120	4	2,750 lbf	25			
LPSC088	PSC-88	111.5	103.5	150	88	150	100	Ø8	27.5	120	3	2400 lbf	25.5			

■ Inventory products

# 5 AXIS PRECISION VISE -DOUBLE LOCK DFV-125

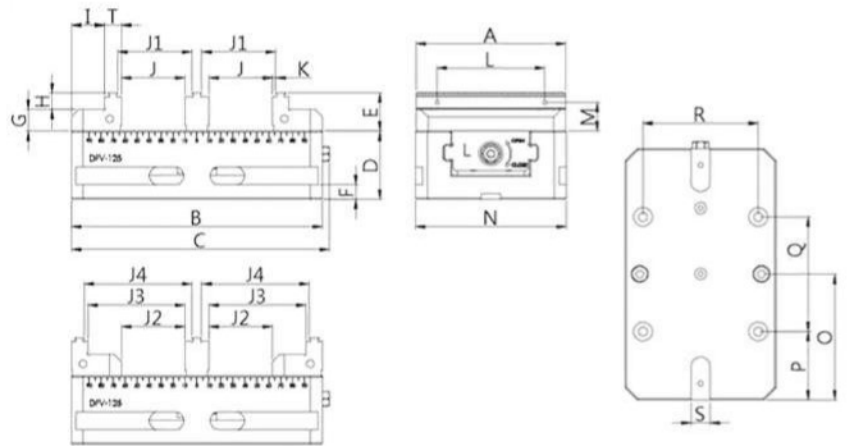

## Specifications

- ▶ It offers high repeatability in clamping and positioning accuracy, up to 0.01mm. It is suitable for precise machining in 4-axis and 5-axis CNC machine tools, indexing heads, and precision vertical/horizontal machining centers.
- ▶ The vise body and components are made of high-grade alloy steel.
- ▶ With a heat-treated hardness of HRC45° , the jaws can securely

訂購編號 Order No.	規格 Spec	A	B	C	D	E	F	G	H	Clamping force	Weight	庫存 Stock	牌價 P	備註2 Remark2
LDFV125	DFV-125	125	210	21.5	57	32	12	18	14	1800 kgf	10.6 kgs			
		I	T	K	L	M	N	O	P					
		28	14	3	90	24	126	105	57					
		Q	R	S	J	J1	J2	J3	J4					
		96	96	16	53	62	53	81	90					

■ Inventory products

# 5-AXIS PRECISION VISE FAV-77

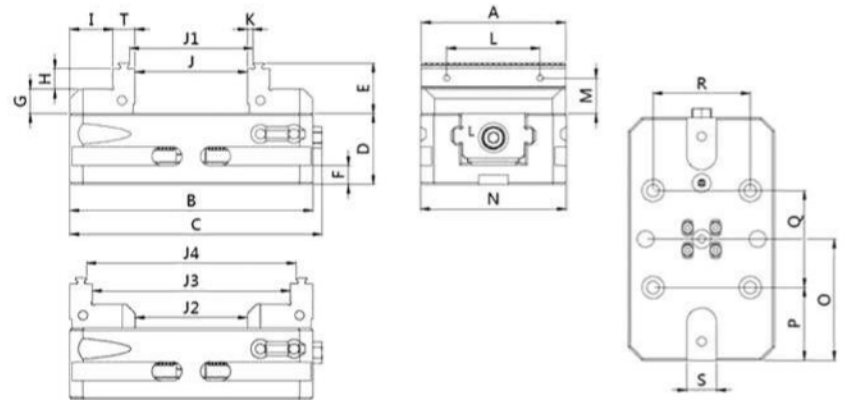

Precision Vise

## Specifications

- ▶ It offers high repeatability in clamping and positioning accuracy, up to 0.01mm. It is suitable for precise machining in 4-axis and 5-axis CNC machine tools, indexing heads, and precision vertical/horizontal machining centers.
- ▶ The vise body and components are made of high-grade alloy steel.
- ▶ The jaws, with a heat-treated hardness of HRC45° ~48° , are capable of securely gripping high-hardness materials.

訂購編號 Order No.	規格 Spec	A	B	C	D	E	F	G	H	Clamping force	Weight	庫存 Stock	牌價 P	備註2 Remark2
LFAV077	FAV-77	77	130	135	38	27	10	13	11	1100 kgf	4 kgs			
		I	T	K	L	M	N	O	P					
		23	12	3	135	19	78	65	39					
		Q	R	S	J	J1	J2	J3	J4					
		52	52	16	60	66	60	106	112					

Inventory products

# SELF CENTERING VISE FCV-100

Precision Vise

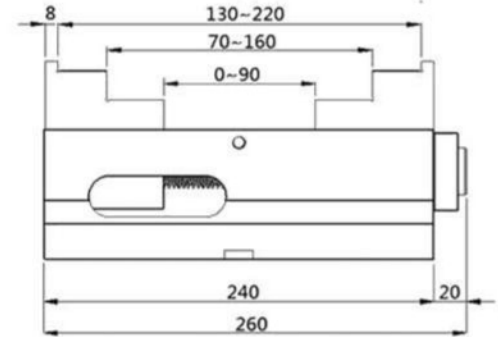
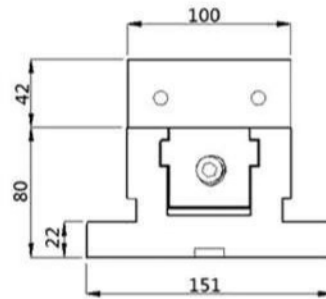

## Specifications

- ▶ The sliding surfaces of the vise body are heat-treated to a hardness of HRC50°, guaranteeing high precision, excellent wear resistance, and superior tensile strength.
- ▶ Its compact length makes it perfectly suited for use with 5-axis integrated machining centers
- ▶ The design with dual-axis simultaneous movement enables precise positioning and machining.

# 5-AXIS PRECISION VISE FAV-125

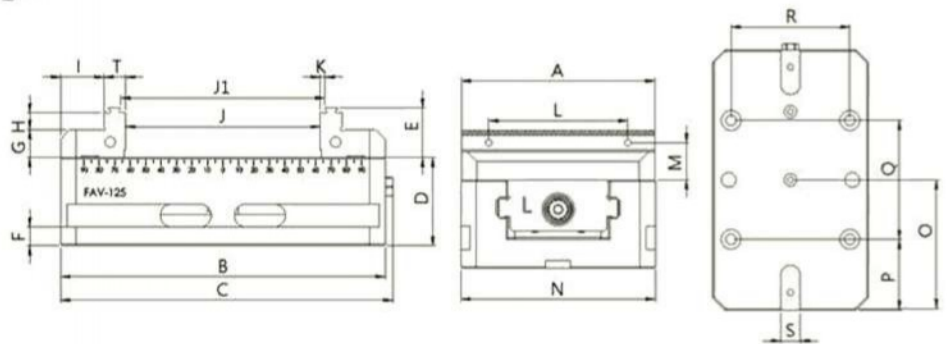
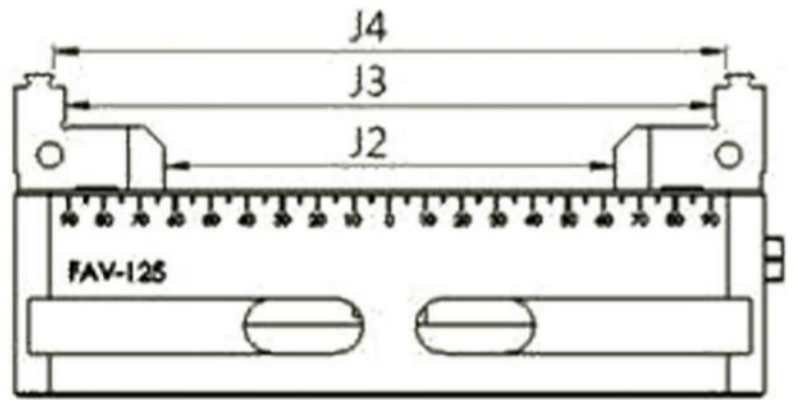

Precision Vise

## Specifications

- ▶ It offers high repeatability in clamping and positioning accuracy, up to 0.01mm. It is suitable for precise machining in 4-axis and 5-axis CNC machine tools, indexing heads, and precision vertical/horizontal machining centers.
- ▶ The vise body and components are made of high-grade alloy steel.
- ▶ With a heat-treated hardness of HRC45° , the jaws can securely grip high-hardness materials with an HRC below 40° .

訂購編號 Order No.	規格 Spec	A	B	C	D	E	F	G	H	Clamping force	Weight	庫存 Stock	牌價 P	備註2 Remark2
LFAV125	FAV-125	125	210	215	57	32	12	18	11	1500 kgf	11 kgs			
		I	T	K	L	M	N	O	P					
		28	14	3	90	24	126	104	57					
		Q	R	S	J	J1	J2	J3	J4					
		96	96	16	126	132	126	182	188					

■ Inventory products

# 5-AXIS PRECISION VISE FAV-125-310L

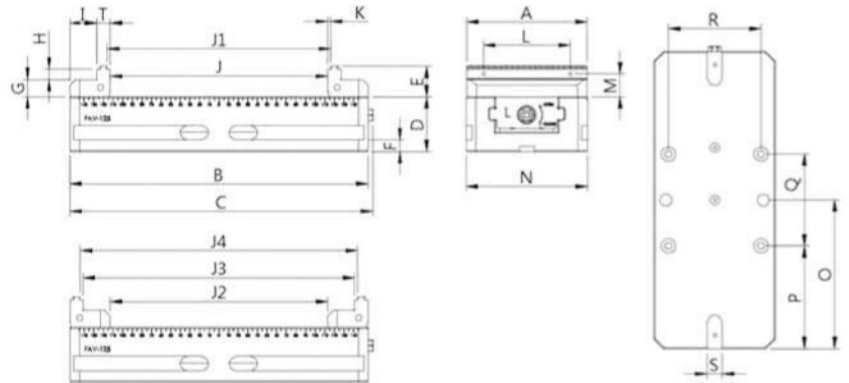

## Specifications

- ▶ It offers high repeatability in clamping and positioning accuracy, up to 0.01mm. It is suitable for precise machining in 4-axis and 5-axis CNC machine tools, indexing heads, and precision vertical/horizontal machining centers.
- ▶ The vise body and components are made of high-grade alloy steel.
- ▶ With a heat-treated hardness of HRC45° , the jaws can securely

訂購編號 Order No.	規格 Spec	A	B	C	D	E	F	G	H	Clamping force	Weight	庫存 Stock	牌價 P	備註2 Remark2
LFAV125310L FAV-125-310L		125	310	315	57	32	12	18	11	1800 kgf				
		I	T	K	L	M	N	O	P					
		28	14	3	90	24	126	155	107					
		Q	R	S	J	J1	J2	J3	J4					
		96	96	16	226	232	226	282	288					

■ Inventory products

# BIG OPEN 5-AXIS PRECISION VISE FAV-220/280

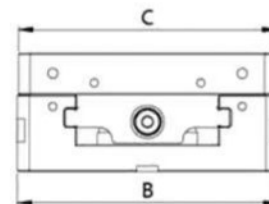
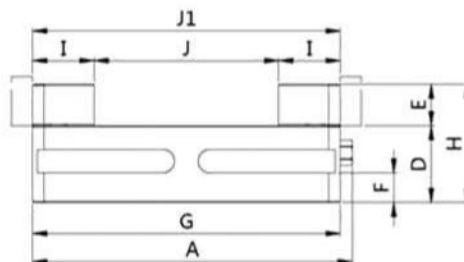

Precision Vise

## Specifications

- ▶ It offers high repeatability in clamping and positioning accuracy, up to 0.015mm. It is suitable for precise machining in 4-axis and 5-axis CNC machine tools, indexing heads, and precision vertical/horizontal machining centers.
- ▶ HRC45° heat-treated jaws can grip high-hardness materials below HRC40°.

訂購編號 Order No.	規格 Spec	A	B	C	D	E	F	G	H	I	J	J1	Clamping force	Weight	庫存 Stock	牌價 P	備註2 Remark2
LFAV220	FPAV-220	270	220	218	65	35	25	260	100	52	156	260	2000 kgf	32kgs			
LFAV280	FAV-280	290	280	278	80	40	25	280	120	62	156	280	2500 kgf	50 kgs			

■ Inventory products

# BIG OPEN 5-AXIS PRECISION VISE FFAV-280(SINGLE WAY)

Precision Vise

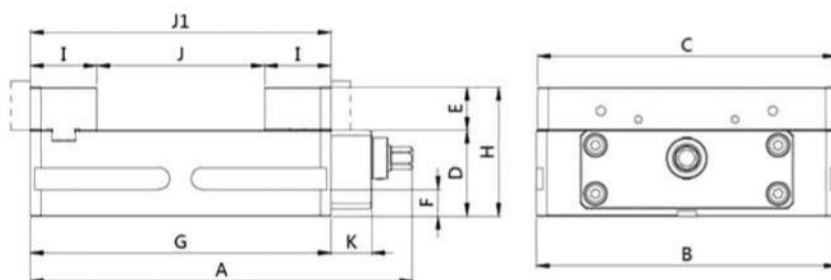

## Specifications

- ▶ It offers high repeatability in clamping and positioning accuracy, up to 0.015mm. It is suitable for precise machining in 4-axis and 5-axis CNC machine tools, indexing heads, and precision vertical/horizontal machining centers.
- ▶ HRC45° heat-treated jaws can grip high-hardness materials below HRC40°.

訂購編號 Order No.	規格 Spec	A	B	C	D	E	F	G	H	I	J	J1	K	Clamping force	Weight	庫存 Stock	牌價 P	備註2 Remark2
LFFAV280	FFAV-280	356	280	278	80	40	25	280	120	62	156	280	38	2500 kgf	57kg			

■ Inventory products

# CNC POWER MACHINE VISE - MACHINE TYPE - MFPV

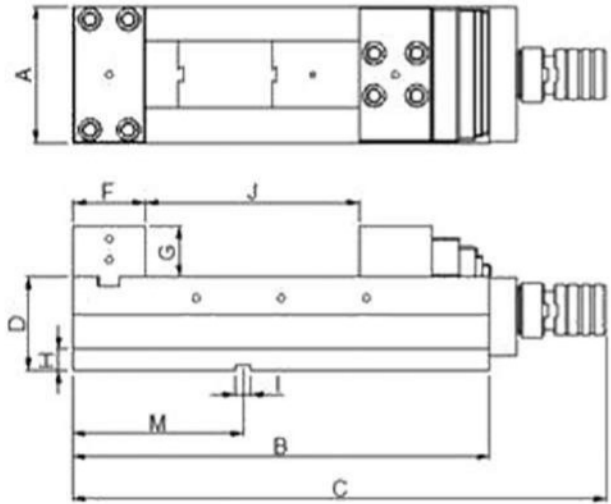

四種夾持方式 Four clamping ways for choice

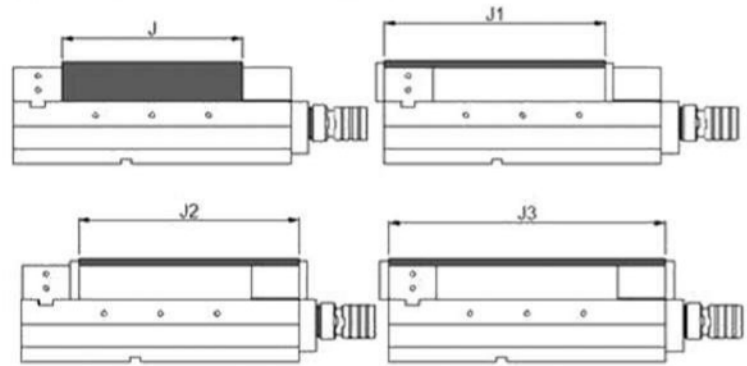

Precision Vise

## Specifications

- ▶ It is suitable for precision machining in vertical/horizontal integrated milling and cutting machining centers.
- ▶ It exhibits high precision, exceptional wear resistance, and outstanding tensile strength.
- ▶ With heat treatment exceeding HRC50°, the product offers high hardness and excellent wear resistance.

訂購編號 Order No.	規格 Spec	A	B	C	D	F	G	H	I	M	J	J1	J2	J3	Clamping force	Weight	庫存 Stock	牌價 P	備註2 Remark2
LMFPV100	MFPV-100	100	310	445	85	75	50	25	18	110	150	210	210	300	3500	30			
LMFPV130	MFPV-130	130	410	545	100	80	55	25	18	135	240	300	300	400	4500	45			
LMFPV160	MFPV-160	160	490	625	110	85	60	25	18	200	300	380	380	480	5000	64			
LMFPV160L	MFPV-160L	160	550	685	110	85	60	25	18	200	360	440	440	540	5000	69			
LMFPV200	MFPV-200	200	530	665	110	85	60	25	18	220	350	420	420	520	5500	86			

Inventory products

# MC POWER MACHINE VISE-MACHINE TYPE - MPPV

Precision Vise

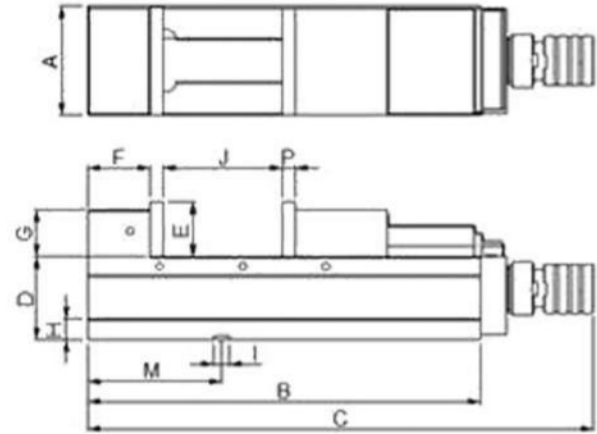

四種夾持方式 Four clamping ways for choice

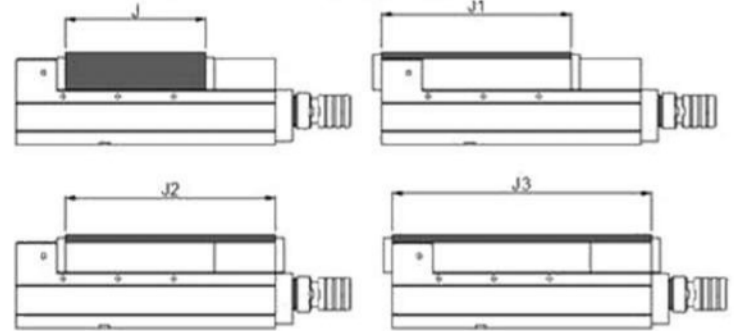

## Specifications

- ▶ It is suitable for precision machining in vertical/horizontal integrated milling and cutting machining centers.
- ▶ It offers a high clamping force of up to 5500kgf with rapid pressure increase.
- ▶ The jaws are heat-treated to achieve a hardness of HRC55° .

訂購編號 Order No.	規格 Spec	A	B	C	D	E	F	G	H	I	M	P	J	J1	J2	J3	Clamping force	Weight	庫存 Stock	牌價 P	備註2 Remark2
LMPPV100	MPPV-100A	100	395	530	85	53	60	50	25	18	110	15	200	280	320	390	3500	28			
LMPPV130	MPPV-130A	130	470	605	100	58	75	55	25	18	160	15	250	340	370	460	4500	45			
LMPPV160	MPPV-160A	160	545	680	100	63	80	60	25	18	200	18	300	390	430	530	5000	64			
LMPPV160S	MPPV-160S	160	488	622	100	63	80	60	25	18	200	18	250	350	390	480	5000	58			
LMPPV160L	MPPV-160L	160	755	885	100	63	90	60	25	18	200	18	500	580	610	700	5000	72			
LMPPV200	MPPV-200A	200	605	740	110	63	95	60	25	18	220	18	340	460	490	600	550	86			

■ Inventory products

# MC PRECISION MACHINE VISE - MV

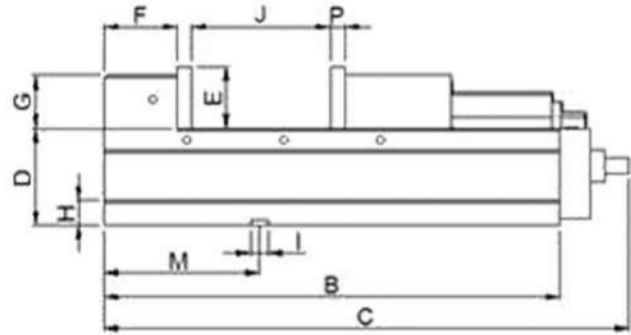
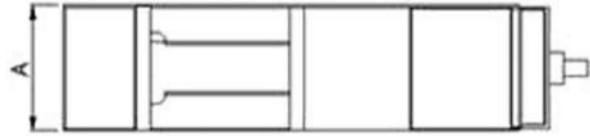

四種夾持方式 Four clamping ways for choice

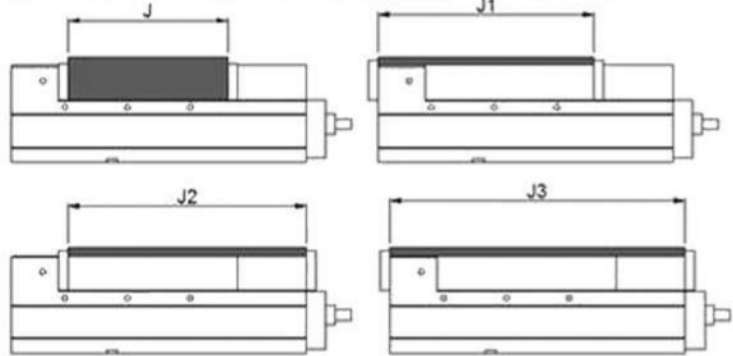

## Specifications

- ▶ It is suitable for precision machining in vertical/horizontal integrated milling and cutting machining centers.
- ▶ It exhibits high precision, exceptional wear resistance, and outstanding tensile strength.
- ▶ The jaws are heat-treated to achieve a hardness of HRC55° .

訂購編號 Order No.	規格 Spec	A	B	C	D	E	F	G	H	I	M	P	J	J1	J2	J3	Weight	庫存 Stock	牌價 P	備註2 Remark2
LMV100	MV-100A	100	395	485	85	53	60	50	25	18	110	15	200	270	310	380	26			
LMV130	MV-130A	130	470	560	100	58	75	55	25	18	160	15	250	330	360	450	44			
LMV160	MV-160A	160	545	635	100	63	80	60	25	18	200	18	300	380	420	520	63			
LMV160S	MV-160S	160	488	580	100	63	80	60	25	18	200	18	250	340	380	470	57			
LMV200	MV-200A	200	605	695	110	63	95	60	25	18	220	18	340	460	490	600	84			

■ Inventory products

Precision Vise

# CNC PRECISION MACHINE VISE - MFV

Precision Vise

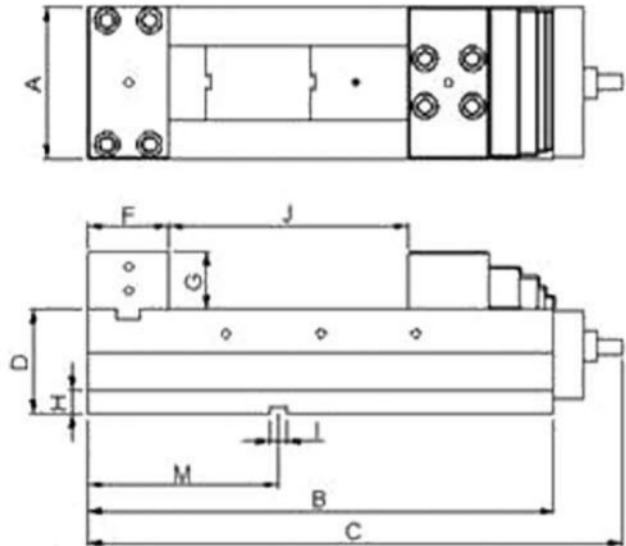

四種夾持方式 Four clamping ways for choice

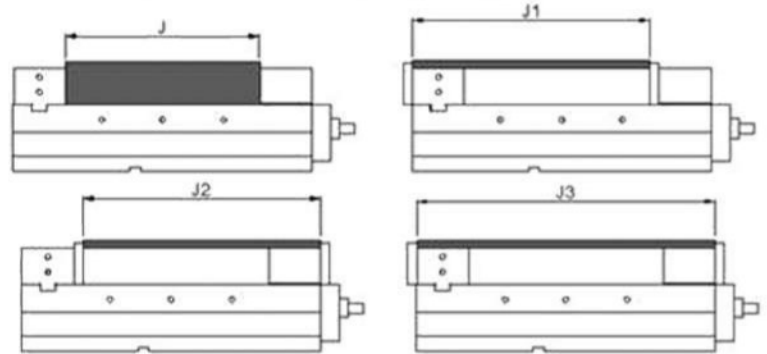

## Specifications

- ▶ It is suitable for precision machining in vertical/horizontal integrated milling and cutting machining centers.
- ▶ It exhibits high precision, exceptional wear resistance, and outstanding tensile strength.
- ▶ With heat treatment exceeding HRC50°, the product offers high hardness and excellent wear resistance.

訂購編號 Order No.	規格 Spec	A	B	C	D	F	G	H	I	M	J	J1	J2	J3	Weight	庫存 Stock	牌價 P	備註2 Remark2
LMFV100	MFV-100	100	310	400	85	75	50	25	18	110	150	210	210	300	29			
LMFV130	MFV-130	130	410	500	100	80	55	25	18	135	240	300	300	400	44			
LMFV160	MFV-160	160	490	580	110	85	60	25	18	200	300	380	380	480	63			
LMFV160L	MFV-160L	160	550	640	110	85	60	25	18	200	360	440	440	540	68			
LMFV200	MFV-200	200	530	620	110	85	60	25	18	220	350	420	420	520	85			

Inventory products